

**Very Low Phase Noise - HCMOS or Sinewave 10MHz to 120MHz**

- Very low phase noise
- Frequency Range: 10MHz - 120MHz
- Excellent stability



**DESCRIPTION**

YH1322 series are high stability OCXOs exhibiting very low phase noise. The part is ideal for use in base station or test equipment applications.

**SPECIFICATIONS**

Frequency Range:	10.0MHz to 120.0MHz
Output:	Sinewave: +10dBm min. into 50Ω
Harmonics:	-20dBc
Temperature Stability:	See table
Freq. vs. Supply:	$\pm 5 \times 10^{-9}$ for a 5% change
Ageing:	$\pm 1 \times 10^{-7}$ per year (10MHz) $\pm 5 \times 10^{-7}$ per year (100MHz)
Input Voltage:	+15.0 VDC $\pm 5\%$ - Option C +12.0 VDC $\pm 5\%$ - Option D
Input Power:	
Warmup:	<6W for 5 minutes
Idle:	<2.5W typical @ +25°C
Warm-up Time:	within $\pm 5 \times 10^{-8}$ in 5 minutes, referenced to 60 minute frequency @ +25°C
Phase Noise:	See table
Frequency Adjustment:	$\pm 1.0$ ppm, typical, Positive slope +0.5 to +5.0 EFC
Shock (optional):	MIL-STD-202, Method 213, Condition C
Vibration (optional):	MIL-STD-202, Method 204, Condition A

Designed and manufactured by Greenray Industries Inc.

**YH1322 - OUTLINES AND DIMENSIONS**

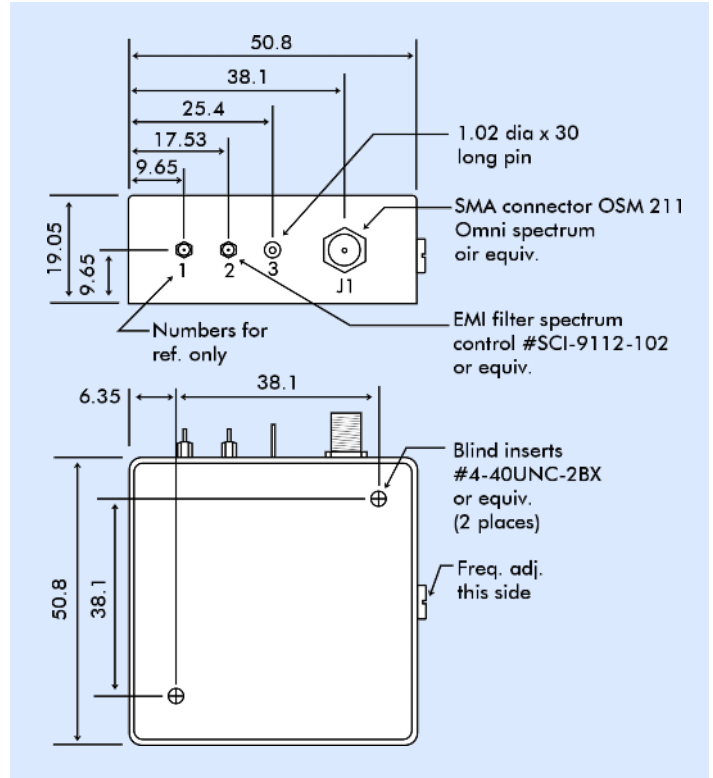

**STABILITY OVER TEMPERATURE**

Temp. Range	Stability 10MHz	Model	Stability 100MHz	Model
0~+50°C	$\pm 1 \times 10^{-8}$	B18	$\pm 5 \times 10^{-8}$	B58
-10~+60°C	$\pm 1.5 \times 10^{-8}$	G158	$\pm 7 \times 10^{-8}$	G78
-20~+70°C	$\pm 2 \times 10^{-8}$	N28	$\pm 1 \times 10^{-7}$	N17
-40~+85°C	$\pm 5 \times 10^{-8}$	T58	$\pm 3 \times 10^{-7}$	T37

**PHASE NOISE**

(Sinewave max.)

Offset	dBc/Hz			
	10MHz Std.	10MHz Ultra-low	100MHz Std.	100MHz Ultra-low
10Hz	-125	-128	-85	-90
100Hz	-150	-155	-115	-120
1kHz	-160	-163	-145	-150
10kHz	-165	-168	-160	-165
100kHz	-165	-168	-165	-168

**PART NUMBERING**

Example: **YH1322-N28-D-UL-10.00MHz**

